

DEPARTMENT OF CONSUMER AND INDUSTRY SERVICES
BUREAU OF SAFETY AND REGULATION
GENERAL INDUSTRY SAFETY STANDARDS COMMISSION

(By authority conferred on the general industry safety standards commission by sections 16 and 21 of Act No. 154 of the Public Acts of 1974, as amended, being SS408.1016 and 408.1021 of the Michigan Compiled Laws)

PART 65. MILLS AND CALENDERS FOR RUBBER AND PLASTIC

R 408.16501 Scope.

Rule 6501. This part provides for the safe maintenance and operation of mills and calenders used in the rubber and plastics trades by employers and their safe use by employees, in, around, and about places of employment.

History: 1979 AC.

R 408.16503 Definitions; A to C.

Rule 6503. (1) "Aisle" means a path of designated travel for employees and vehicles.

(2) "Calender" means a machine equipped with 2 or more metal rolls in vertical frames and revolving in opposite directions used for continuously sheeting or plying up rubber and plastic compounds and for frictioning or coating materials with rubber and plastic compounds.

History: 1979 AC.

R 408.16506 Definitions; M to S.

Rule 6506. (1) "Mill" means a machine consisting of 2 adjacent metal rolls, set horizontally, which revolve in opposite directions and which are used for the mechanical working of rubber and plastic compounds.

(2) "Nip point" means the point where a rotating object creates a pinching action with another rotating object.

(3) "Safety device" means a guard such as, but not limited to, a barrier, enclosure, body bar, safety rod or safety cable used to protect an employee from a hazardous condition.

History: 1979 AC.

R 408.16511 Employers' responsibilities.

Rule 6511. An employer shall:

- (a) Provide training to an employee as to the hazards and safe operation of his assigned job.
- (b) Maintain the mills and calenders in a condition free of recognized hazards.
- (c) Establish and maintain a lockout procedure as prescribed in R 408.16527.

History: 1979 AC.

R 408.16512 Employees' responsibilities.

Rule 6512. An employee shall:

- (a) Not use a mill or calender unless authorized and trained in its use.

(b) Not remove a guard or safety device from a mill or calender except when necessary for servicing or where equivalent safety is provided. The guard shall be replaced before restarting the machine. All safety devices shall be replaced and tested before a mill or calender is put back into operation.

(c) Report defective machinery, equipment and hazardous conditions, when detected, to his supervisor.

History: 1979 AC.

R 408.16515 Illumination.

Rule 6515. Illumination shall be provided to maintain a minimum of 20 footcandles intensity at an operator's work station.

History: 1979 AC.

R 408.16517 Floors and aisles.

Rule 6517. (1) An aisle or floor area around a mill or calender shall be maintained free of protruding objects, holes, oil, grease, and accumulations of water.

(2) The surface of a platform or floor area at an operator's work station shall be maintained in slip-resistant condition.

(3) An aisle for combined usage of employees and stock moving equipment shall be 3 feet wider than the widest load moved. The outline of the aisle shall be marked or otherwise identified. When an oversized load is moved, pedestrian traffic shall be warned ahead of the load movement. Where stock moving equipment is not used in an aisle, the aisle shall not be less than 3 feet wide.

History: 1979 AC.

R 408.16521 Installation.

Rule 6521. (1) A mill or calender shall be secured in a manner to prevent unintentional movement.

(2) Such a machine, except where installed in a laboratory, shall not be so placed as to require an operator to stand in an aisle.

(3) A mill installed or moved after the effective date of this part shall be installed so that the top of the operating rolls is not less than 50 inches above the floor or the operator's working level.

(4) Installation of auxiliary equipment, such as but not limited to feeding and stock removing equipment and blending rolls, shall be guarded by location, barriers, or enclosures so as to not create a hazard. The auxiliary equipment shall not interfere with access or operation of a safety device.

(5) A mill or calender shall be electrically grounded.

History: 1979 AC.

R 408.16523 Hot surfaces.

Rule 6523. Steam and hot water pipes and surfaces of machinery exposed to contact, except the mill and calender rolls, which would cause burns, shall be covered with an insulating material or guarded by a barrier.

History: 1979 AC.

R 408.16525 Ventilation.

Rule 6525. Materials processed on a mill or calender, which give off noxious or toxic materials that exceed the maximum allowable limits set by the Michigan department of public health, shall be equipped with a ventilation system approved for this use.

History: 1979 AC.

R 408.16527 Maintenance.

Rule 6527. (1) A power source of a mill, calender or their auxiliary equipment to be repaired, serviced or set up shall be locked out by each employee doing the work if unexpected start up would cause injury. Residual pressure shall be relieved before and during such work when maintenance is performed on a pressurized system.

(2) A braking or safety device for a mill or calender shall be inspected and tested weekly. The stopping distances shall be measured and recorded. Where the braking action does not meet or exceeds the requirements of R 408.16542 and R 408.16546, repairs or adjustments shall be made before operation is resumed.

History: 1979 AC.

R 408.16528 Lubrication.

Rule 6528. (1) Lubrication shall be accomplished by 1 of the following:

- (a) Manually when the machine can be shut off and locked out.
- (b) An automatic pressure or gravity feed system.
- (c) An extension pipe leading to an area outside of guards or away from any hazard.
- (d) Other means providing safety equal to or exceeding subdivision (a), (b), or (c).

(2) In any case rule 732 of the occupational safety standards commission standard, Part 7. Guards for Power Transmission, being R 408.10732 of the Michigan Administrative Code, shall be followed.

History: 1979 AC.

R 408.16531 Steam pressure procedures.

Rule 6531. (1) Where a pressure reducing valve is used, not less than 1 relief valve, set at not more than the rated pressure of the equipment, shall be provided adjacent to the reducing valve on the low pressure side. The relief valve shall vent to an area which will not create a hazard to an employee.

(2) A steam valve to machinery shall be opened slowly to avoid uneven expansion of a pressure chamber.

(3) A cylinder-type machine shall be in motion before steam is admitted.

(4) The rated operating steam pressure of a machine shall not be exceeded.

History: 1979 AC.

R 408.16541 Mill safety devices.

Rule 6541. (1) Except where an employee cannot come in contact with a roll nip point or be caught between a roll and an adjacent object because of a fixed installation, a mill shall be provided with 1 of the following safety trip devices to actuate braking equipment:

(a) A pressure sensitive bar which can be tripped by not more than a 40-pound pressure of an employee's body. The bar shall be installed at the front and back of the mill across the length of the rolls of each mill roll having a height of 46 inches or more. (See figure 1)

(b) A safety rod or safety cable installed at the front and back of a mill and located within 2 inches of a vertical plane tangent to the front and rear rolls. The safety rod or cable shall not be more than 72 inches from the floor of the operator's work level and operate with either a push or pull motion.

(2) A mill having automatic overhead blending rolls shall have the blender interlocked to the mill so that actuation of the mill safety device will stop the blender.

(3) A safety device, after actuation, shall require manual resetting.

(4) A laboratory mill may be guarded by an interlocked barrier in lieu of the requirements of subrule (1).

Figure for 408.16541

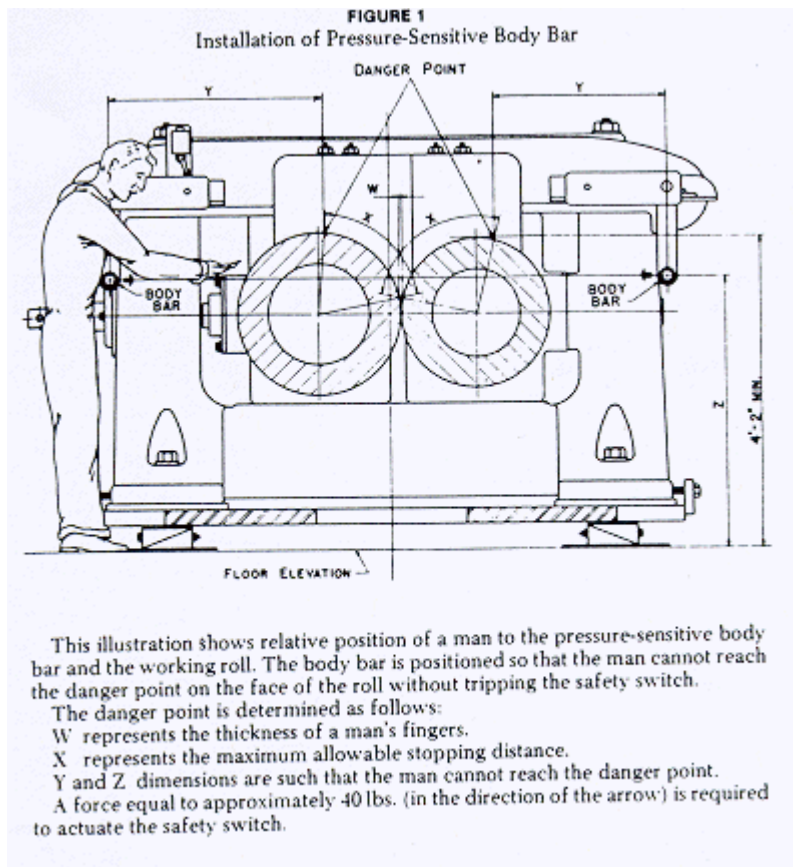

History: 1979 AC.

R 408.16542 Mill stopping limits.

Rule 6542. A mill, regardless of roll size or roll arrangement, shall be stopped by braking equipment within a distance, measured in inches of surface travel of the faster roll, of not more than 1 1/2% of the peripheral no-load surface speed of the roll as determined in feet per minute. (See figure 2)

Figure for 408.16542

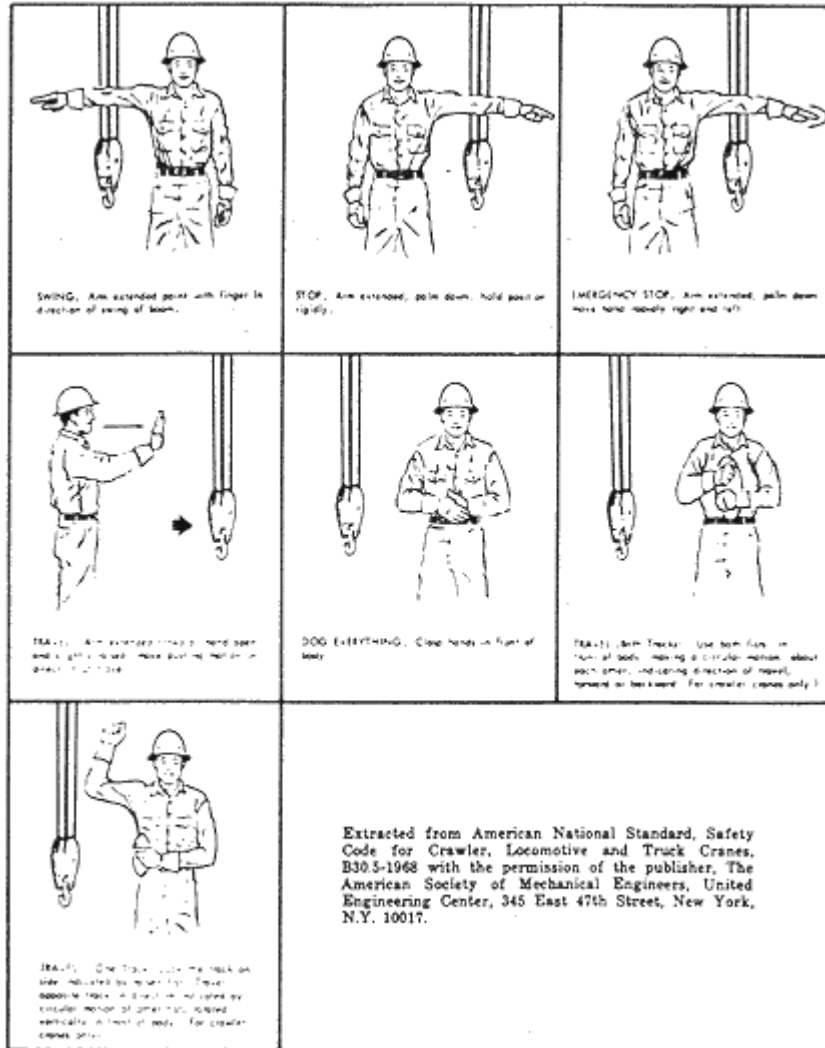

Extracted from American National Standard, Safety Code for Crawler, Locomotive and Truck Cranes, B30.5-1968 with the permission of the publisher, The American Society of Mechanical Engineers, United Engineering Center, 345 East 47th Street, New York, N.Y. 10017.

All measurements on mills shall be taken with the rolls running empty at maximum operating speed. Stopping distances shall be expressed in inches of surface travel of the faster roll from the instant the emergency stopping device is actuated.

History: 1979 AC.

R 408.16545 Calender safety devices.

Rule 6545. (1) Except where an employee cannot come in contact with a roll nip point or be caught between a roll and an adjacent object because of a fixed installation, a calender shall be provided with the following safety trip devices to actuate braking equipment:

(a) A safety rod or cable located across each pair of inrunning rolls and extending the length of the rolls. The device shall operate with either a push or pull motion. The safety tripping devices shall be located within reach of the operator at the bite.

(b) A safety cable shall be run vertically on both sides of the calender and connected to the safety switch. The cable shall be not more than 12 inches from the face of the rolls and not less than 2 inches from

the calender frame. The cable shall be anchored not more than 6 inches from the floor and operated with either a push or pull motion.

(2) A safety device, after actuation, shall require manual resetting.

History: 1979 AC.

R 408.16546 Calender stopping limits.

Rule 6546. A calender, regardless of size or configuration, shall be stopped by braking equipment within a distance, measured in inches of surface travel of the fastest roll, of not more than $1\frac{3}{4}$ % of the peripheral no-load surface speed of the calender rolls as determined in feet per minute. (See figure 3)

**** INSERT MISSING TABLE OR CHART - SEE ORIGINAL MANUSCRIPT ****

All measurements on calenders shall be taken with the rolls running empty at maximum operating speed. Stopping distances shall be expressed in inches of surface travel of the fastest roll from the instant the emergency stopping device is actuated.

History: 1979 AC.