

**DEPARTMENT OF LICENSING AND REGULATORY AFFAIRS**

**DIRECTOR'S OFFICE**

**CONSTRUCTION SAFETY STANDARDS**

(By authority conferred on the director of the department of licensing and regulatory affairs by sections 19 and 21 of 1974 PA 154, and Executive Reorganization Order Nos. 1996-2, 2003-1, 2008-4, and 2011-4, MCL 445.2001, 445.2011, 445.2025, and 445.2030)

**PART 11. FIXED AND PORTABLE LADDERS**

**R 408.41101 Scope .**

Rule 1101. This part establishes minimum requirements for the construction, care, and training in the use of portable and fixed ladders for construction, alteration, or repair operations .

History: 1979 AC; 1993 AACS .

**R 408.41102 Rescinded.**

History: 1979 AC; 2013 AACS.

**R 408.41103 Definitions; B to I .**

Rule 1103. (1) "Brand" means marking by burning with a hot iron .

(2) "Cage," "cage guard," or "basket guard" means an enclosure that is fastened to the side rails of a fixed ladder or to the structure to encircle the climbing space of a ladder for the safety of a climber .

(3) "Cleats" means a ladder's crosspieces of rectangular cross section which are placed on edge and on which a person may step to ascend or descend .

(4) "Double-cleat ladder" means a ladder that is similar to a single-cleat ladder, but is wider and has an additional rail in the center that allows simultaneous 2-way traffic

(5) "Equivalent" means alternative designs, materials, or methods that will provide an equal or greater degree of safety for employees .

(6) "Extension ladder" means a non-self-supporting portable ladder that is adjustable in length. An extension ladder consists of 2 or more sections traveling in guides or brackets arranged to permit adjustment of the ladder's length. An extension ladder's size is designated by the sum of the lengths of the sections measured along the side rails .

(7) "Extension trestle ladder" means a self-supporting portable ladder which is adjustable in length, which consists of a trestle ladder base and a vertically adjustable

single ladder, and which has suitable means for locking the ladders together. The size is designated by the length of the rail of the trestle ladder base .

(8) "Fixed ladder" means a ladder that is permanently attached to a structure, building, or equipment .

(9) "Grab bar" means a handhold that is placed adjacent to, or as an extension above, a ladder for the purpose of providing access beyond the limits of the ladder .

(10) "Individual rung ladder" means a fixed ladder that has each rung individually attached to a structure, building, or equipment .

History: 1979 AC; 1990 AACS; 1993 AACS .

#### **R 408.41104 Definitions; J to R .**

Rule 1104. (1) "Job-built ladder" means a ladder, other than a manufactured ladder, that is usually built at the jobsite .

(2) "Ladder" means an appliance that usually consists of 2 side rails which are joined at regular intervals by crosspieces which are called steps, rungs, or cleats and on which a person may step to ascend or descend .

(3) "Ladder safety device" means a device, other than a cage or well, that is designed to eliminate or reduce the possibility of accidental falls .

(4) "Lower levels" means those levels to which an employee can fall from a ladder. Such areas include ground levels, floors, ramps, runways, excavations, pits, water, and similar surfaces. The term does not include the surface from which the employee falls .

(5) "Manufactured ladder" means a commercially made ladder .

(6) "Maximum intended load" means the total load of all employees, equipment, tools, materials, transmitted loads, and other loads that are anticipated to be applied to a ladder compartment at any one time .

(7) "Pitch" means the included angle which is between the horizontal and the ladder and which is measured on the opposite side of the ladder from the climbing side .

(8) "Platform ladder" means a self-supporting type of fixed size stepladder that has a platform provided at the working level. The size is determined by the distance along the front rail from the platform to the base of the ladder .

(9) "Portable ladder" means a ladder which is not permanently fixed in place and which may be used at various locations .

(10) "Rail ladder" means a fixed ladder which consists of side rails that are joined at regular intervals by rungs or cleats and which is fastened along its entire length or in sections to a building, structure, or equipment .

(11) "Rungs" means a ladder's crosspieces of circular or oval cross section on which a person may step to ascend or descend .

History: 1979 AC; 1993 AACS .

#### **R 408.41105 Definitions; S to W .**

Rule 1105. (1) "Safety feet" means a safety device that is placed on the foot of the side rails of straight, sectional, or extension ladders to reduce the likelihood that the

base will slip. Safety feet may be flat pads that are covered with a nonslip material, pointed metal projections, or spur wheels .

(2) "Side-step ladder" means a ladder that requires an employee who is getting off at the top of the ladder to step sideways from the ladder to reach the landing .

(3) "Single-cleat ladder" means a ladder which consists of a pair of parallel side rails that are connected with cleats which are joined to the side rails at regular intervals .

(4) "Single-rail ladder" means a portable ladder that has rungs, cleats, or steps which are mounted on a single rail instead of the normal 2 rails that are used on most other ladders

(5) "Special-purpose ladder" means a portable ladder that represents either a modification or a combination of design or construction features in 1 or more of the general purpose types of ladders, as defined in R 408.41103(5) and (6), R 408.41104(5) and (6), and subrules (4) and (6) of this rule, in order to adapt the ladder to special or specific uses .

(6) "Stepladder" means a self-supporting portable ladder which is nonadjustable in length and which has flat steps and a hinged back. A stepladder's size is measured along the front edge of the side rails .

(7) "Steps" means the flat crosspieces of a ladder on which a person may step to ascend or descend .

(8) "Through ladder" means a ladder that requires an employee who is getting off at the top of the ladder to step through the ladder to reach the landing .

(9) "Trestle ladder" means a self-supporting portable ladder which is nonadjustable in length and which consists of 2 sections that are hinged at the top to form equal angles with the base. The size of the ladder is designated by the length of the side rails measured along the front edge .

(10) "Well" means a permanent complete enclosure around a fixed ladder that protects a climber. Proper clearance for a well will give the same protection as a cage .

(11) "Worn" means a reduction of the dimension of a wood or nonwood part by more than 10% of its original size .

History: 1979 AC; 1990 AACS; 1993 AACS .

#### **R 408.41111. Adoption by reference; certification.**

Rule 1111. (1) A manufactured portable wood ladder shall be constructed and maintained as prescribed in the ANSI standard A14.1-1990, which is adopted by reference in this rule and may be inspected at the Lansing office of the department of licensing and regulatory affairs. This standard may be purchased at a cost as of the time of adoption of this rule of \$36.00 from Global Engineering Documents, 15 Inverness Way East, Englewood, Colorado, 80112, telephone number 1-800-854-7179, website: [www.global.ihs.com](http://www.global.ihs.com), or from the Michigan Department of Licensing and Regulatory Affairs, 7150 Harris Drive, Box 30643, Lansing, Michigan 48909.

(2) A manufactured portable metal ladder shall be constructed and maintained as prescribed in the ANSI standard A14.2-1990, which is adopted by reference in this rule and may be inspected at the Lansing office of the department of licensing and regulatory affairs. This standard may be purchased at a cost as of the time of adoption of this rule of \$41.00 from Global Engineering Documents, 15 Inverness Way East, Englewood,

Colorado, 80112, telephone number 1-800-854-7179, website: [www.global.ihs.com](http://www.global.ihs.com), or from the Michigan Department of Licensing and Regulatory Affairs, 7150 Harris Drive, Box 30643, Lansing, Michigan 48909.

(3) A manufactured portable plastic ladder shall be constructed and maintained as prescribed in the ANSI standard A14.5-1982 and supplement 1985, which is adopted by reference in this rule and may be inspected at the Lansing office of the department of licensing and regulatory affairs. This standard may be purchased at a cost as of the time of adoption of this rule of \$42.00 from Global Engineering Documents, 15 Inverness Way East, Englewood, Colorado, 80112, telephone number 1-800-854-7179, website: [www.global.ihs.com](http://www.global.ihs.com), or from the Michigan Department of Licensing and Regulatory Affairs, 7150 Harris Drive, Box 30643, Lansing, Michigan 48909.

(4) Fixed ladders shall be constructed and maintained as prescribed in the ANSI standard A14.3-1984, which is adopted by reference in this rule and may be inspected at the Lansing office of the department of licensing and regulatory affairs. This standard may be purchased at a cost as of the time of adoption of this rule of \$20.00 from Global Engineering Documents, 15 Inverness Way East, Englewood, Colorado, 80112, telephone number 1-800-854-7179, website: [www.global.ihs.com](http://www.global.ihs.com), or from the Michigan Department of Licensing and Regulatory Affairs, 7150 Harris Drive, Box 30643, Lansing, Michigan 48909.

(5) A manufactured portable ladder shall be branded or have a permanent label permanently affixed by the manufacturer which shows the type of ladder and certifies that it meets the requirements of the appropriate ANSI standard as set out in subrules (1) to (4) of this rule.

History: 1979 AC; 1990 AACS; 1993 AACS; 2013 AACS.

#### **R 408.41112 Training requirements .**

Rule 1112. (1) The employer shall provide a training program for each employee who uses a ladder. The program shall enable each employee to recognize hazards related to the ladder and shall train each employee in the procedures to be followed to minimize these hazards .

(2) An employer shall ensure that each employee has been trained by a competent person in all of the following areas, as applicable: (a) The nature of fall hazards in the work area .

(b) The correct procedures for erecting, maintaining, and disassembling the fall protection systems to be used .

(c) The proper construction, use, and placement of, and care in handling, ladders .

(d) The maximum intended load-carrying capacities of ladders that are used .

(e) The rules contained in this part .

(3) Retraining shall be provided for each employee as necessary so that the employee maintains the understanding and knowledge acquired through compliance with these rules .

History: 1993 AACS .

**R 408.41113 General requirements .**

Rule 1113. (1) A ladder shall be provided at all personnel points of access if there is a break in elevation of 19 inches (48 cm) or more and if a ramp, runway, sloped embankment, stairway, or personnel hoist is not provided .

(2) When a building or structure has only 1 point of access between levels, that point of access shall be kept clear to permit the free passage of employees. When work must be performed or equipment must be used, that restricts the free passage of employees at the point of access, a second point of access shall be provided and used .

(3) When a building or structure has 2 or more points of access between levels, at least 1 point of access shall be kept clear to permit the free passage of employees .

(4) Employers shall provide and install all ladder fall protection systems that are required by this part and shall comply with all other pertinent requirements of this part before employees begin the work that necessitates the installation and use of ladders and their respective fall protection systems .

(5) Ladder rungs, cleats, and steps shall be parallel, level, and uniformly spaced when a ladder is in position for use .

(6) Rungs, cleats, and steps of portable ladders, except as provided in subrules (7) and (8) of this rule, and fixed ladders shall be spaced not less than 10 inches (25 cm) apart and not more than 14 inches (36 cm) apart, as measured between the center lines of the rungs, cleats, and steps .

(7) Rungs, cleats, and steps of step stools shall be not less than 8 inches (20 cm) apart and not more than 12 inches (31 cm) apart, as measured between center lines of the rungs, cleats, and steps .

(8) Rungs, cleats, and steps of the base section of extension trestle ladders shall be not less than 8 inches (20 cm), nor more than 18 inches (46 cm), apart, as measured between center lines of the rungs, cleats, and steps. The rung spacing on the extension section of the extension trestle ladder shall be not less than 6 inches (15 cm), nor more than 12 inches (31 cm), as measured between center lines of the rungs, cleats, and steps .

(9) The minimum clear distance between the sides of individual rung-type stepladders and the minimum clear distance between the side rails of other fixed ladders shall be 16 inches (41 cm) .

(10) The minimum clear distance between side rails for all portable ladders shall be 11 1/2 inches (29 cm) .

(11) The rungs of individual rung-type stepladders shall be shaped so that an employee's feet cannot slide off the end of the rungs. See figure

1 .

FIGURE 1

SUGGESTED DESIGN FOR RUNGS ON INDIVIDUAL RUNG LADDERS

**Figure for 408.41113**

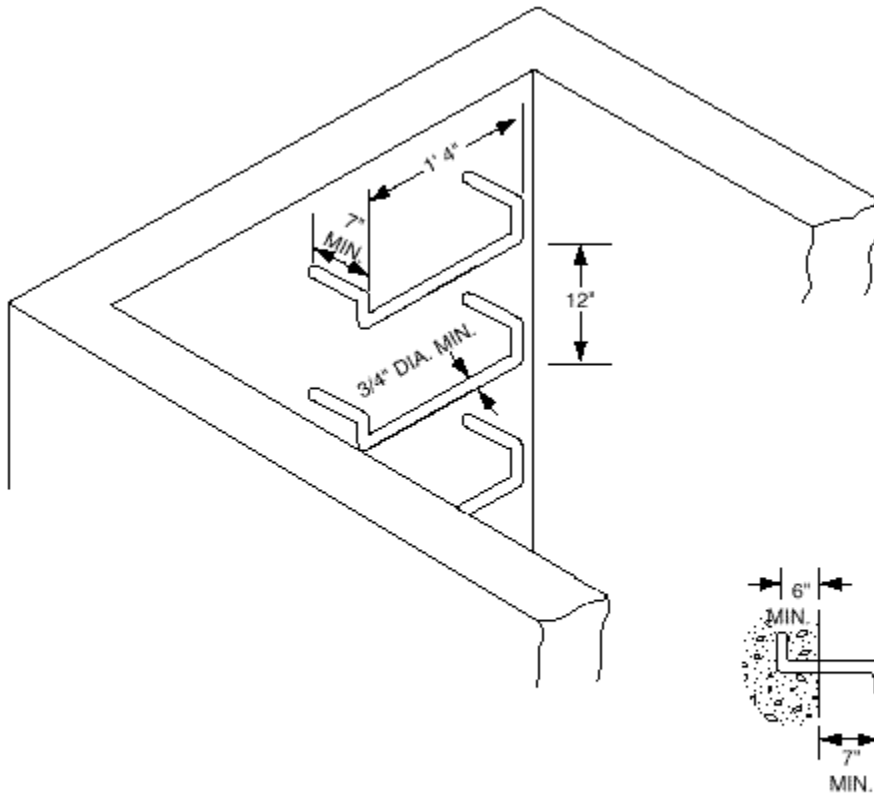

**FIGURE 1  
SUGGESTED DESIGN FOR RUNGS  
ON INDIVIDUAL RUNG LADDER**

(12) The rungs and steps of fixed metal ladders that are manufactured after January 14, 1991, shall be corrugated, knurled, dimpled, coated with skid-resistant material, or otherwise treated to minimize slipping .

(13) The rungs of steps of portable metal ladders shall be corrugated, knurled, dimpled, coated with skid-resistant material, or otherwise treated to minimize slipping.

(14) Except when portable ladders are used to gain access to fixed ladders, such as ladders on utility towers, billboards, and other structures where the bottom of the fixed ladder is elevated to limit access, when 2 or more separate ladders are used to reach an elevated work area, the ladder shall be offset with a platform or landing between the ladders .

(15) Ladder components shall be surfaced in a manner that prevents employee injury due to punctures or lacerations and prevents the snagging of clothing .

History: 1993 AACS .

**R 408.41115 Rescinded.**

History: 1993 AACS; 2013 AACS.

**R 408.41121 Inspection; faults and defects .**

Rule 1121. (1) A ladder, as prescribed in this part, shall be used to provide safe access to all elevations, unless other means, such as steps, stairs, ramps, runways, or elevators, are provided .

(2) A ladder shall be inspected before use and after it has fallen or been involved in an accident to determine its condition .

(3) A ladder that has any of the following faults and defects shall be immediately tagged "DANGEROUS - DO NOT USE" and shall be withdrawn from service:

- (a) Broken, worn, or missing rungs, cleats, or steps .
- (b) Broken or split side rails .
- (c) Broken or bent guides or iron spreaders .
- (d) Broken or bent locks .

The tag shall be as prescribed in rules 2241 and 2242 of Part 22. Signals, Signs, Tags and Barricades, being R 408.42241 and R 408.42242 of the Michigan Administrative Code .

(4) Fixed ladders that have structural defects, such as broken or split rails or corroded components, shall be withdrawn from service until repaired. The requirement to withdraw a defective ladder from service is satisfied if 1 of the following provisions is complied with:

- (a) The ladder is immediately tagged with the words "do not use" or similar language .
- (b) The ladder is marked in a manner that readily identifies it as defective.
- (c) The ladder is blocked, such as with a plywood attachment that spans several rungs .

(5) Ladder repairs shall restore the ladder to a condition that meets its original design criteria before the ladder is returned to use .

History: 1979 AC; 1990 AACS; 1993 AACS .

**R 408.41122. Use generally.**

Rule 1122. (1) A ladder shall not be placed in a passageway, doorway, driveway, or any location where it may be displaced, unless it is protected by barricades or guards or is secured to prevent displacement.

(2) A ladder shall be placed on a substantial and stable base unless it is secured to prevent accidental displacement. The area around the top and bottom of the ladder shall be kept clear.

(3) A ladder shall not be used as a brace, slide, guy, gin pole, or gangway or for any other use than that for which it is designed.



(4) An employee shall face the ladder when ascending or descending. Each employee shall use at least 1 hand to grasp the ladder when progressing up or down the ladder. An employee shall not carry any object or load that could cause the employee to lose balance and fall.

(5) An employee who is on a ladder shall not overreach or do any pushing or pulling that may cause the ladder to move or topple. If both of an employee's shoulders are outside of a side rail, the employee is overreaching.

(6) A ladder shall be located and maintained to prevent an employee from bumping into, or snagging onto, projecting objects while ascending or descending the ladder.

(7) A ladder shall not be loaded beyond its load-carrying capacity.

(8) A ladder shall not be moved, shifted, or extended while occupied by an employee.

(9) Single-rail ladders shall not be used.

History: 1979 AC; 1990 AACS; 1993 AACS; 2013 AACS.

#### **R 408.41123. Classification of ladders.**

Rule 1123. The use of all manufactured portable ladders or stepladders shall be limited to those classified as type IA or type I, as prescribed in ANSI A14.1-1990, which is adopted by reference in this rule and may be inspected at the Lansing office of the department of licensing and regulatory affairs. This standard may be purchased from Global Engineering Documents, 15 Inverness Way East, Englewood, Colorado, 80112, telephone number 1-800-854-7179, website: [www.global.ihs.com](http://www.global.ihs.com), or from the Michigan Department of Licensing and Regulatory Affairs, MIOSHA Standards Section, 7150 Harris Drive, Box 30643, Lansing, Michigan 48909, at a cost as of the time of adoption of this rule of \$36.00.

History: 1979 AC; 1990 AACS; 1993 AACS; 2013 AACS.

#### **R 408.41124. Portable ladders.**

Rule 1124. (1) A portable ladder shall be used at such a pitch that the horizontal projected distance from the top support to the base is not more than 1/4 of the vertical distance between these points.

(2) A portable ladder in use shall be equipped with appropriate safety feet, unless the ladder is tied, blocked, or otherwise secured to prevent it from being displaced. Slip-resistant feet shall not be used as a substitute for care in placing, lashing, or holding a ladder that is used upon slippery surfaces, including flat metal or concrete surfaces that are constructed so that they cannot be prevented from becoming slippery.

(3) A portable ladder that is used at such a pitch that the horizontal projected distance from the top support to the base is less than 1/5 of the vertical distance between these points shall be secured at the top to prevent tipping backward.

(4) A portable ladder that is used at a pitch of 80 degrees or more shall be in compliance with the requirements of a fixed ladder as prescribed in R 408.10335.

(5) When portable ladders are used for access to an upper landing surface, the ladder side rails shall extend not less than 3 feet (.9 m) above the upper landing surface to



which the ladder is used to gain access; or, when such an extension is not possible because of the ladder's length, then the ladder shall be secured at its top to rigid support that will not deflect and a grasping device, such as a grabrail, shall be provided to assist employees in mounting and dismounting the ladder. The side rails shall not extend in a manner that would permit ladder deflection under a load, by itself, to cause the ladder to slip off its support. The top of a non-self-supporting ladder shall be placed with the 2 rails supported equally, unless the ladder is equipped with a single support attachment.

(6) A manufactured portable metal ladder shall not be used for electrical work or where the ladder or an employee may contact electrical conductors. A ladder shall have nonconductive siderails if the ladder is used where the employee or the ladder could contact exposed energized electrical equipment.

(7) A metal ladder shall not be used or moved unless a minimum of 20 feet is maintained between power transmission or distribution lines.

(8) A power transmission or distribution line or electrical apparatus shall be considered energized unless the property owner or utility indicates it is de-energized and the line or apparatus is visibly grounded. Where de-energizing is impractical, the minimum clearances set forth in table 1 shall be maintained between the ladder, employee, or material, whichever is closer.

(9) Table 1 reads as follows:

| VOLTAGE    | MINIMUM CLEARANCE           |
|------------|-----------------------------|
| To 50 kV   | 10 feet                     |
| Over 50 kV | 10 feet plus .4 inch per kV |

(10) An employee who is using a portable ladder shall not stand on the top 2 rungs or within 3 feet of the top of the ladder.

(11) Two portable ladders shall not be spliced together to provide long sections unless such ladders are specifically designed for such use.

(12) A portable 2-section extension ladder shall be erected so that the top section rests on the base section. The top section shall be the section nearest to the climber.

(13) A non-self-supporting ladder shall be used at an angle such that the horizontal distance from the top support to the foot of the ladder is approximately 1/4 of the working length of the ladder that is the distance along the ladder between the foot and the top support.

(14) A fixed ladder shall be used at a pitch of not more than 90 degrees from the horizontal, as measured to the back side of the ladder. See figure 5.

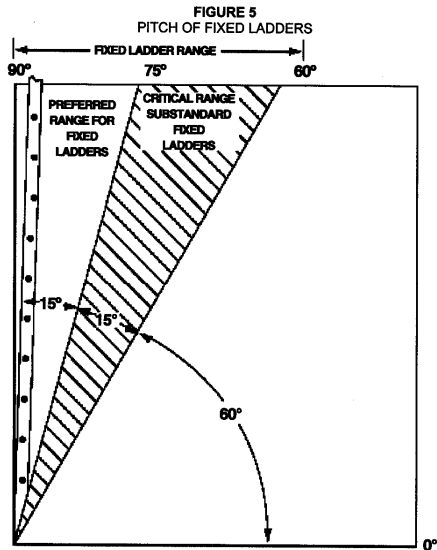

History: 1979 AC; 1990 AACS; 1993 AACS; 2013 AACS.

**R 408.41125 Rescinded.**

History: 1979 AC; 1993 AACS; 2013 AACS.

**R 408.41126. Use of stepladders.**

Rule 1126. (1) An employee shall not use the backside of a stepladder for climbing, unless the stepladder is designed for such use.

(2) Unless the stepladder is equipped with a handrail, the top step and cap shall not be used to stand on.

(3) A stepladder shall not be used as a straight ladder by leaning it against a wall or other support.

(4) A metal spreader or locking device shall be provided on each stepladder to hold the front and back sections in an open position when the ladder is being used. The ladder shall be opened fully and the spreaders shall be locked while in use.

History: 1979 AC; 1993 AACS; 2013 AACS.

**R 408.41127 Single and double-cleat ladders generally .**

Rule 1127. (1) A job-built ladder shall not be more than 24 feet in length. If the length of a required job-built ladder would be more than the maximum length, 2 or more separate ladders shall be used and shall be offset with a platform between each ladder that is not supported by the ladders. Ladders used with a platform shall be secured at the top and bottom .

(2) The platform shall be designed to support 4 times the intended load .

Guardrails and toeboards, as prescribed in Part 45. Fall Protection, being R 408.44501 et seq. of the Michigan Administrative Code, shall be erected on the exposed sides of the platform. Rails shall extend above the top landing at least 36 inches but not more than 42 inches to provide a handhold for mounting and dismounting, and cleats shall be eliminated above the landing level. When 2 or more separate job-built ladders are used with a platform, the ladders shall be completely offset from each other and the minimum horizontal distance between adjacent side rails shall be 6 inches .

(3) Side rails of a job-built ladder shall be continuous .

(4) Each cleat of a job-built ladder shall be a continuous member .

(5) A wood cleat shall be not less than nominal 1-inch by 4-inch construction grade lumber for a cleat less than 20 inches in length and not less than nominal 2-inch by 4-inch construction grade lumber for a cleat from 20 inches to 50 inches in length. Knot-free lumber shall be used for cleats .

(6) The cleats shall be uniformly spaced 12 inches top to top. A cleat shall be attached to the narrow face of each side rail using 2 10-d nails for nominal 1-inch by 4-inch cleats or 2 16-d nails for 2-inch by 4-inch cleats .

(7) Filler blocks shall be used on the rails between cleats. Filler blocks of the same thickness as the cleats shall be inserted between cleats and butted tightly against the underside of each cleat .

(8) Side rails shall not be cut into house cleats .

History: 1979 AC; 1990 AACS; 1996 AACS .

#### **R 408.41128 Single-cleat ladders; width; side rails .**

Rule 1128. (1) The width of a single-cleat ladder shall be not less than 16 inches or more than 20 inches between rails. Side rails shall be parallel .

(2) Side rails of a single-cleat ladder shall be not less than nominal 2-inch by 4-inch construction grade lumber for ladders less than 16 feet in length and not less than nominal 2-inch by 6-inch construction grade lumber for ladders from 16 feet to 24 feet in length .

History: 1979 AC; 1990 AACS .

#### **R 408.41129 Double-cleat ladders; width; additional rail; side rails .**

Rule 1129. (1) The width between outside rails of a double-cleat ladder shall be not less than 38 inches or more than 46 inches .

(2) A double-cleat ladder shall have an additional rail located at the center of the ladder

(3) The side rails and middle rail for a double-cleat ladder shall be not less than nominal 2-inch by 4-inch construction grade lumber for double-cleat ladders less than 12 feet in length and not less than nominal 2-inch by 6-inch construction grade lumber for a double-cleat ladder from 12 feet to 24 feet in length .

(4) The side rails of a double-cleat ladder shall be secured at the bottom and as close as possible to the top to prevent moving or toppling .

History: 1990 AACCS .

**R 408.41130 Rescinded.**

History: 1990 AACCS; 2013 AACCS.

**R 408.41131 Rescinded.**

History: 1979 AC; 1990 AACCS; 2013 AACCS.

**R 408.41132. Maintenance.**

Rule 1132. (1) A ladder shall be maintained free of slip-enhancing hazards and in good working condition.

(2) A ladder shall not be painted with an opaque material. A ladder, particularly one used out-of-doors should be coated with a suitable transparent protective material to retard splintering caused by weathering.

(3) The side rails and legs of a ladder shall be kept free from splinters. The joint between the side rail and step shall be kept tight and metal hardware and fittings secured.

(4) A ladder surface shall be free of puncture or laceration hazards.

History: 1990 AACCS; 2013 AACCS.

**R 408.41133. Special-purpose ladders.**

Rule 1133. (1) A special-purpose ladder may be capable of being used as a step ladder, a single or extension ladder, or a trestle ladder.

(2) A special-purpose ladder, when used as any of the types of ladders listed in subrule (1) of this rule, shall meet the requirements of the applicable rules of this part.

(3) A special-purpose ladder may be used by more than 1 employee if specifically designed for that purpose.

History: 1990 AACCS; 2013 AACCS.

**R 408.41140. Fixed ladders.**

Rule 1140. A fixed ladder shall be as prescribed in Part 3. Fixed ladders, being R 408.10301 et seq. of the Michigan Administrative Code. This standard may be inspected at or purchased from the Michigan Department of Licensing and Regulatory Affairs, MIOSHA Standards Section, 7150 Harris Drive, Box 30643, Lansing, Michigan 48909.

History: 1990 AACCS; 2013 AACCS.